

Win-Vent Architectural Windows 2401 S. Main Street Fort Scott Kansas 66701
(620) 223-1111 (800) 295-3113 Fax (620) 223-1139 www.winventwindows.com

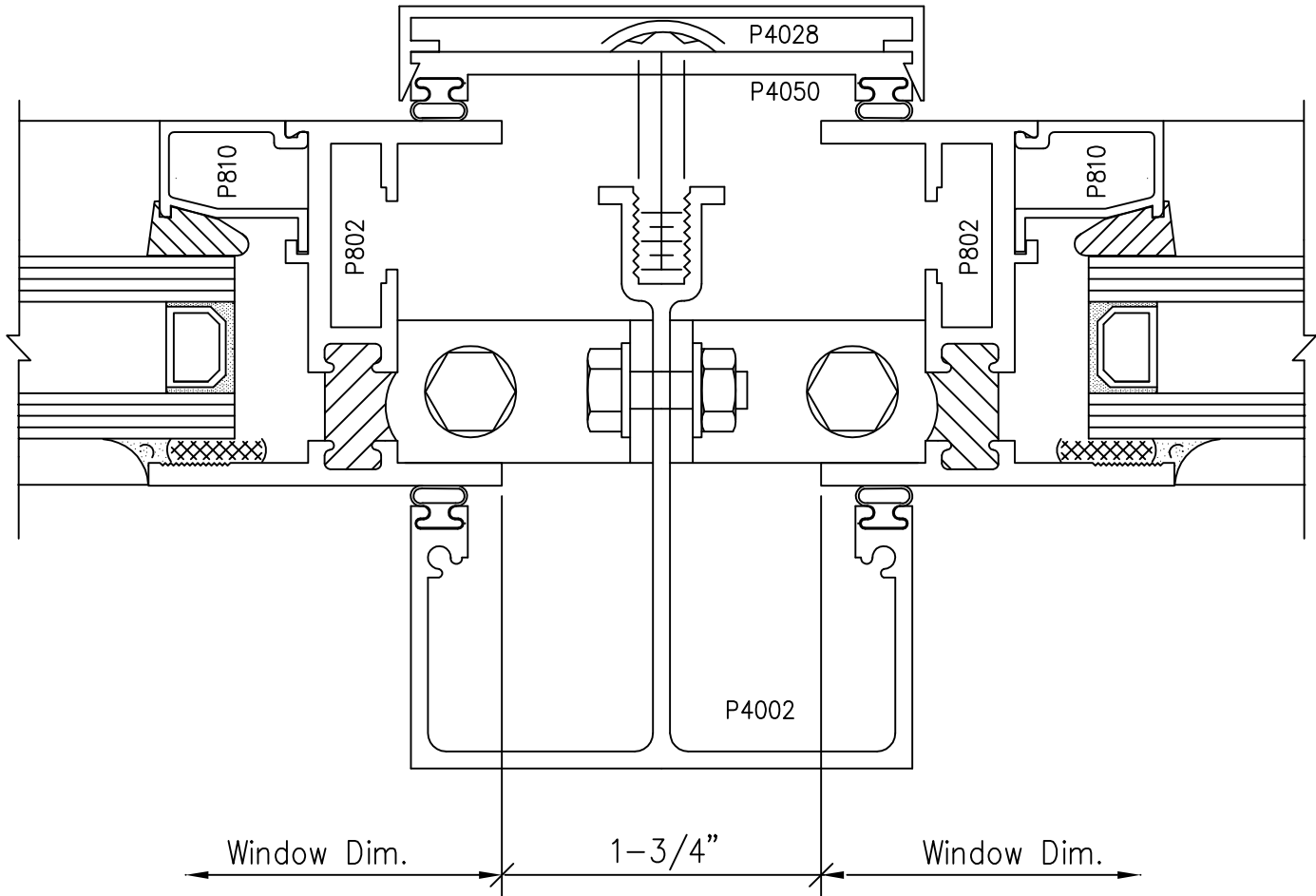

1 Detail M-2
A2

2" x 2" x 1/8" x 1" LONG ALUMINUM ANGLE CLIPS SUPPLIED BY WIN-VENT FOR FIELD INSTALL (1 EACH SIDE OF MULLION TOP AND BOTTOM) WITH 1/4" LOCKING BOLTS. ANCHOR MULLION THRU CLIPS WITH 1/4" FASTENERS BY INSTALLER.

UNLESS OTHERWISE SPECIFIED, ALL MULLIONS WILL BE SHIPPED 2" LONGER THAN OPENING DIMENSION FOR FIELD TRIM AS REQUIRED. ATTACH MULL PLATE WITH 1/4" PAN HEAD MACHINE SCREWS SUPPLIED BY WIN-VENT, THRU PASSAGE HOLES APPLIED AT 18" ON CENTER, SEAL HEADS.

ALL STRUCTURAL PERFORMANCE INQUIRIES SHOULD BE DIRECTED TO WIN-VENT.